

THIS DRAWING AND THE DATA DISCLOSED HEREIN OR HEREWITH IS NOT TO BE REPRODUCED USED OR DISCLOSED IN WHOLE OR IN PART TO ANYONE WITHOUT THE PERMISSION OF JESS-LINK PRODUCTS CO.,LTD.

CUSTOMER DRAWING

REV.	DESCRIPTION	MDF'D	APP'D	DATE
02	MODIFY DRAWING	Brown	Matsu	07/07/2014
03	ADD PIN DIM	Brown	Matsu	07/09/2014
04	ADD PACKING	Brown	Matsu	12/27/2014

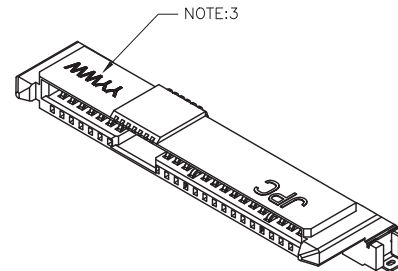
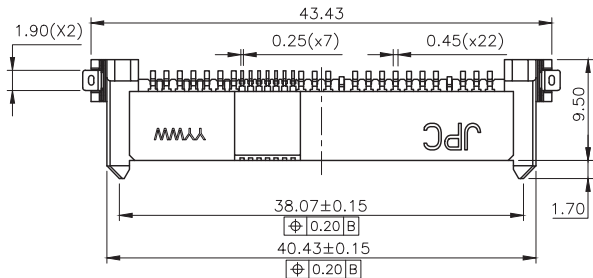

NOTE:

- MATERIAL:
HOUSING/CAP: HI-TEMP THERMOPLASTIC UL 94V-0 BLACK
TERMINAL/SOLDER TAB: COPPER ALLOY
- PLATING:
TERMINAL: 30u" MIN GOLD ON MATING AREA
100u" MIN MATTE TIN ON SOLDER AREA
50u" MIN NICKEL UNDERPLATE ALL OVER
SOLDER TAB: 50u" MIN NICKEL UNDERPLATE OVER
100u" MIN MATTE TIN ALL OVER

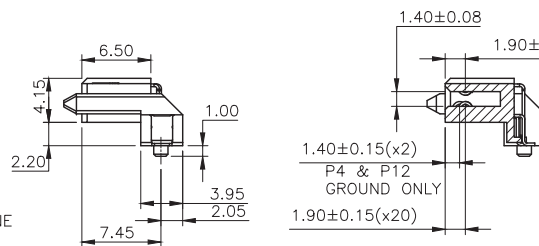
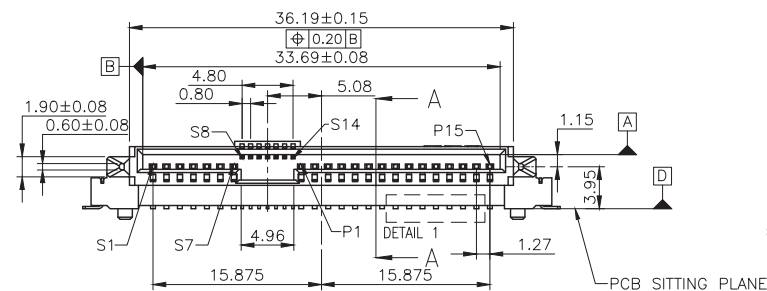

SECTION A-A

- DATE CODE: YYWW
YY=YEAR OF MANUFACTURE
WW=WEEK OF MANUFACTURE
- PACKAGE: TAPE & REEL
- P/N: MARTAX:
JPC P/N: P 9 2 7 D 0 2 9 3 F 0 R - 0

SFF 8680 RECEPTACLE
R/A SMT SERIES
(H=3.95mm)

POS:
029: 29PIN

PACKAGE
R : TAPE & REEL

O: FOR MST BLALE NOT APPLICABLE

F: SMT BLADE

CONNECTOR PLATING
2:MATING -15u' Au / TAIL MATT TIN
3:MATING -30u' Au / TAIL MATT TIN

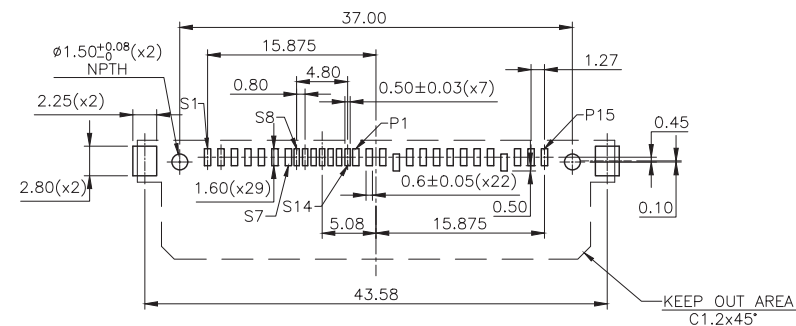
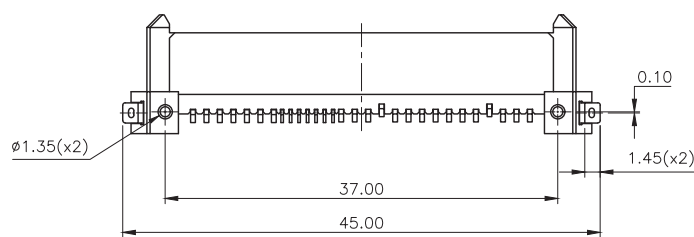

RECOMMENDED PCB LAYOUT

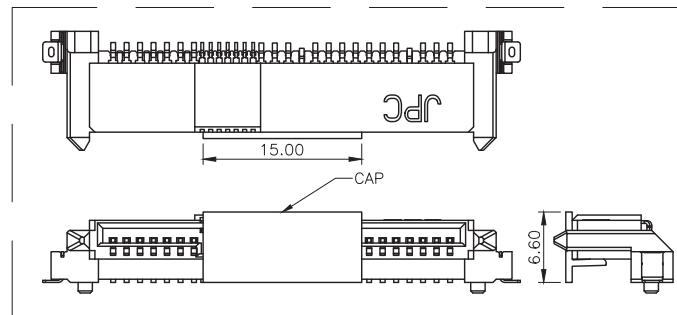
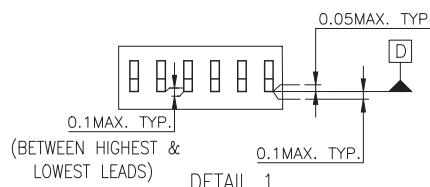

ROHS COMPLIANT	HALOGEN FREE	Unit : mm	PROJECTION		JESS-LINK PRODUCTS CO.,LTD.		PRODUCT NO. OR LAYOUT C14H0302A		
		GENERAL TOLERANCES: (UNLESS SPECIFIED)							
		0 = ±.45	D.R. Brown 05/21/2014	TITLE		SCALE	SIZE	PART NO.	REV. 04
		0.0 = ±.30	CH.K 05/21/2014	SFF 8680 SAS 29PIN CONNECTOR (RECEPTACLE,R/A,SMT,H=3.95mm)					
0.00 = ±.20	James	AP.V.D 05/21/2014	Matsu						

THIS DRAWING AND THE DATA DISCLOSED HEREIN OR HEREWITH IS NOT TO BE REPRODUCED USED OR DISCLOSED IN WHOLE OR IN PART TO ANYONE WITHOUT THE PERMISSION OF JESS-LINK PRODUCTS CO.,LTD.

CUSTOMER DRAWING

REV.	DESCRIPTION	MDF'D	APP'D	DATE
02	MODIFY DRAWING	Brown	Matsu	07/07/2014
03	ADD PIN DIM	Brown	Matsu	07/09/2014
04	ADD PACKING	Brown	Matsu	12/27/2014

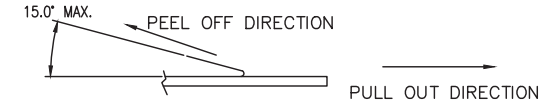
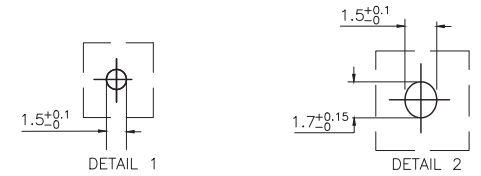
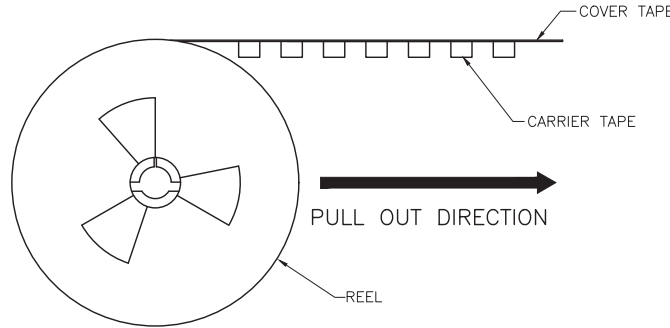
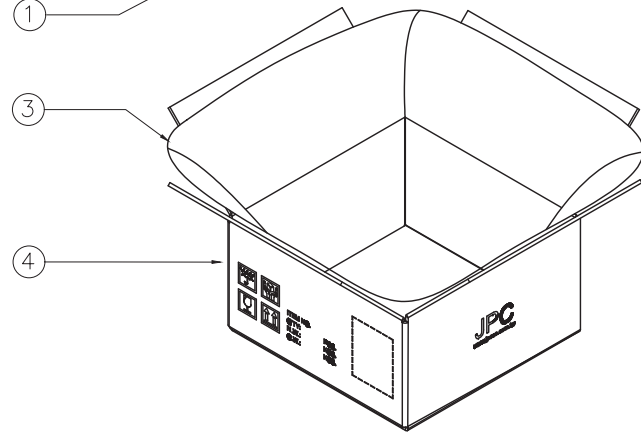
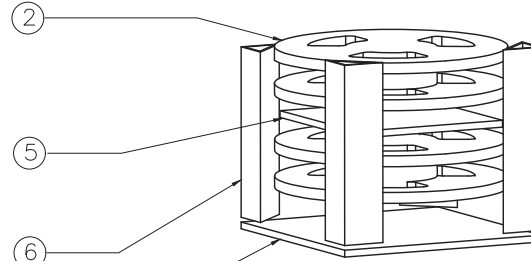
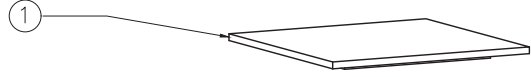
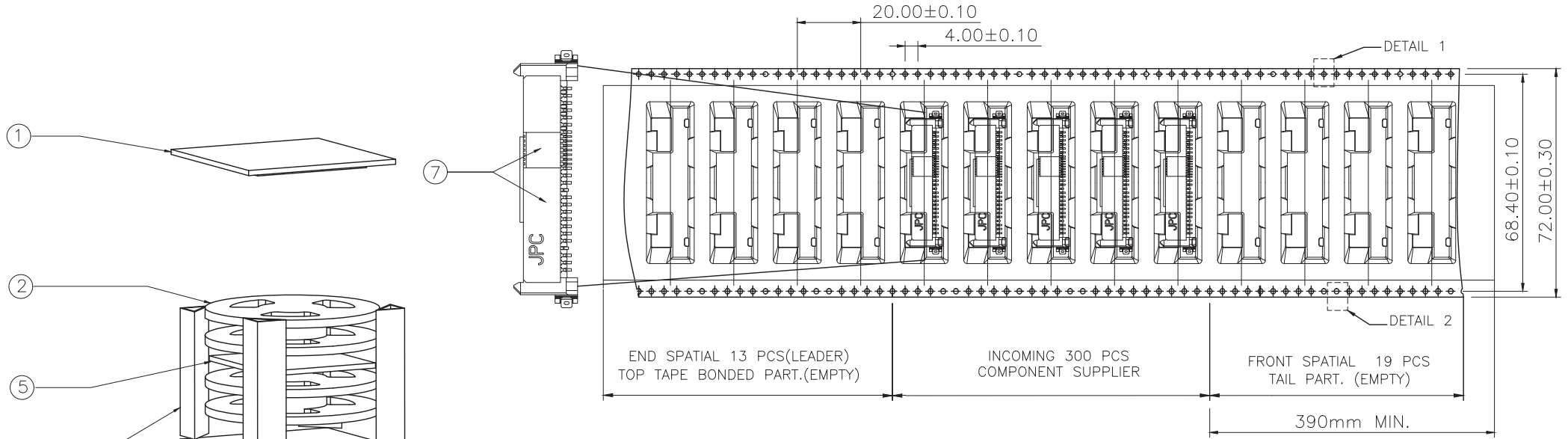

PEELING OFF FORCE TEST

NOTE:

1. PEELING OFF FORCE OF THE TOPTAPE: 20-150gf.
2. TAPE AND REEL QUANTITY: 300PCS/REEL.

ITEM	DESCRIPTION	Q'TY
9		
8		
7	SFF 8680 SAS 29PIN (RECEPTACLE,VERTICAL,SMT)	900
6	EDGE BOARD, 370X240X5mm	4
5	BUBBLE BAG, 325X325X5mm	1
4	MASTER CARTON, 332X332X260mm	1
3	WATERPROOF PE BAG, 500X*(175+175)X650mm T=0.05mm	1
2	TAPE & REEL 13" CARRIER TAPE W=72mm & REEL ø330x72.9mm	3
1	PAPER PAD, 325X325X3mm	2

ROHS COMPLIANT

HALOGEN FREE

Unit : mm
GENERAL TOLERANCES: (UNLESS SPECIFIED)
0 = ±.45
0.0 = ±.30
0.00 = ±.20
0.000 = ±.10
0° = ±.2°
0.0° = ±.1°

PROJECTION
D.R. Brown 12/27/2014
CH.K James 12/27/2014
APV.D Matsu 12/27/2014

JESS-LINK PRODUCTS CO.,LTD.
TITLE: SFF 8680 SAS 29PIN CONNECTOR (RECEPTACLE,R/A,SMT,H=3.95mm)
SCALE: 2:1
SIZE: A3
PART NO.: P927D0293FOR-0
REV. 04
PRODUCT NO. OR LAYOUT: C14H0302A
SH.T NO.2 OF 2