

THIS DRAWING AND THE DATA DISCLOSED HEREIN OR HEREWITH IS NOT TO BE REPRODUCED USED OR DISCLOSED IN WHOLE OR IN PART TO ANYONE WITHOUT THE PERMISSION OF JESS-LINK PRODUCTS CO.,LTD.

CUSTOMER DRAWING

REV.	DESCRIPTION	MDF'D	APP'D	DATE
03	MODIFY DRAWING	Brown	Matsu	03/06/2015
04	MODIFY DESIGN	Brown	Matsu	04/30/2015
05	MODIFY DRAWING	Brown	Matsu	05/08/2015

- NOTE:
- MATERIAL:
HOUSING/CAP: HI-TEMP THERMOPLASTIC UL 94V-0 BLACK
TERMINAL/FORKLOCK: COPPER ALLOY
 - PLATING:
TERMINAL: 30u" MIN GOLD ON MATING AREA
100u" MIN MATTE TIN ON SOLDER AREA
50u" MIN NICKEL UNDERPLATE ALL OVER
FORKLOCK: 50u" MIN NICKEL UNDERPLATE OVER
100u" MIN MATTE TIN ALL OVER
 - DATE CODE: YYWW
YY=YEAR OF MANUFACTURE
WW=WEEK OF MANUFACTURE
 - PACKAGE: TAPE & REEL
 - P/N: MATRIX:
JPC P/N: P 9 2 7 B 0 2 2 3 F 1 R - 0

SFF 8680 RECEPTACLE
R/A SMT RESERVE SERIES
(H=5.00mm)

POS: 022: 22PIN

PACKAGE R : TAPE & REEL

1: FORKLOCK TAIL= 2.25mm

F: FORKLOCK

CONNECTOR PLATING

2:MATING -15u" Au / TAIL MATT TIN

3:MATING -30u" Au / TAIL MATT TIN

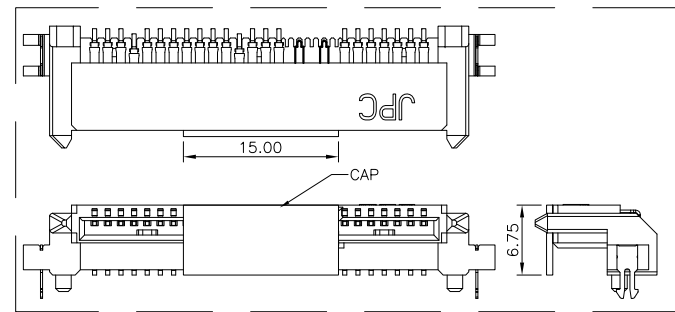
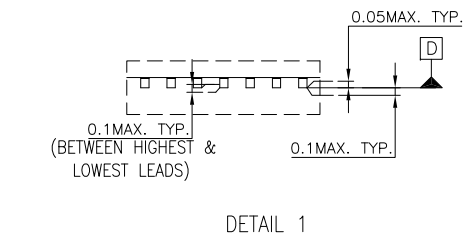
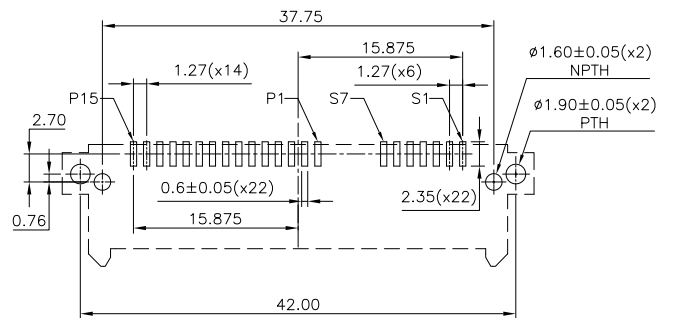
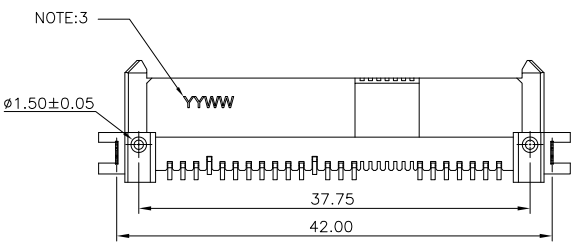
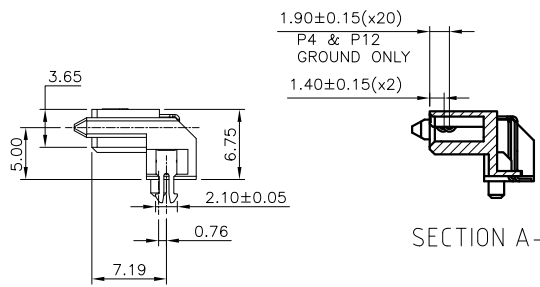
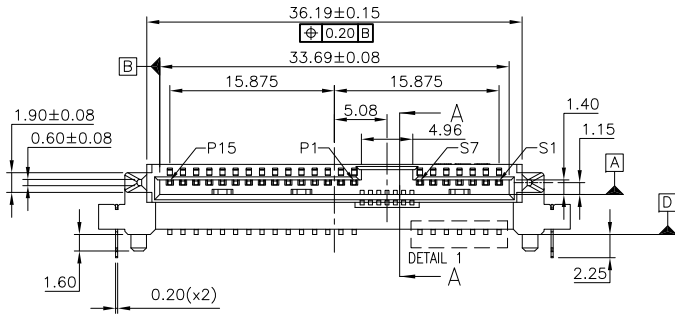
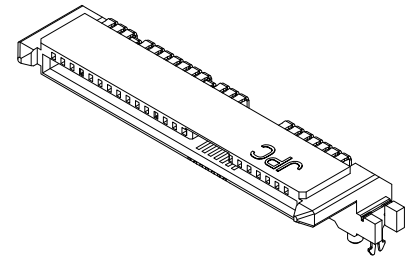
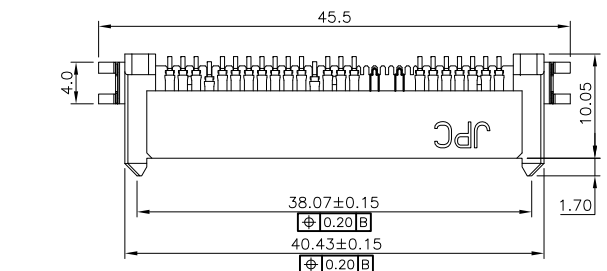

ROHS COMPLIANT	HALOGEN FREE	Unit : mm	PROJECTION	JESS-LINK PRODUCTS CO.,LTD.		PRODUCT NO. OR LAYOUT
		GENERAL TOLERANCES: (UNLESS SPECIFIED)		D.R. 01/30/2015	TITLE	C15H0304B
		0 = ±.45	Brown	01/30/2015	SFF 8680 SAS 22PIN CONNECTOR (Rec.,REVERSE R/A,SMT,H=5.00mm)	
		0.0 = ±.30	CH.K 01/30/2015	James	SCALE	SIZE
0.000 = ±.20	APV.D 01/30/2015	Matsu	2:1	A3	P927B0223F1R-0	SH.T NO.1 OF 1
0' = ±.10						
0' = ±.2'						
0.0' = ±.1'						