

THIS DRAWING AND THE DATA DISCLOSED HEREIN OR HEREWITH IS NOT TO BE REPRODUCED USED OR DISCLOSED IN WHOLE OR IN PART TO ANYONE WITHOUT THE PERMISSION OF JESS-LINK PRODUCTS CO.,LTD.

CUSTOMER DRAWING

REV.	DESCRIPTION	MDF'D	APP'D	DATE
01	INITIAL DESIGN	Bob	Roy	09/30/2016
04	MODIFY PRODUCT DESCRIPTION	Jemmy	Ray	09/18/2017
05	PITCH28mm change to PITCH24mm	denghong	Pc Liao	07/20/2018

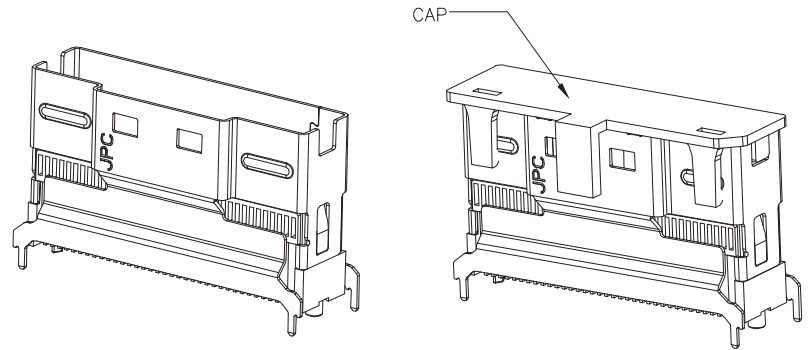
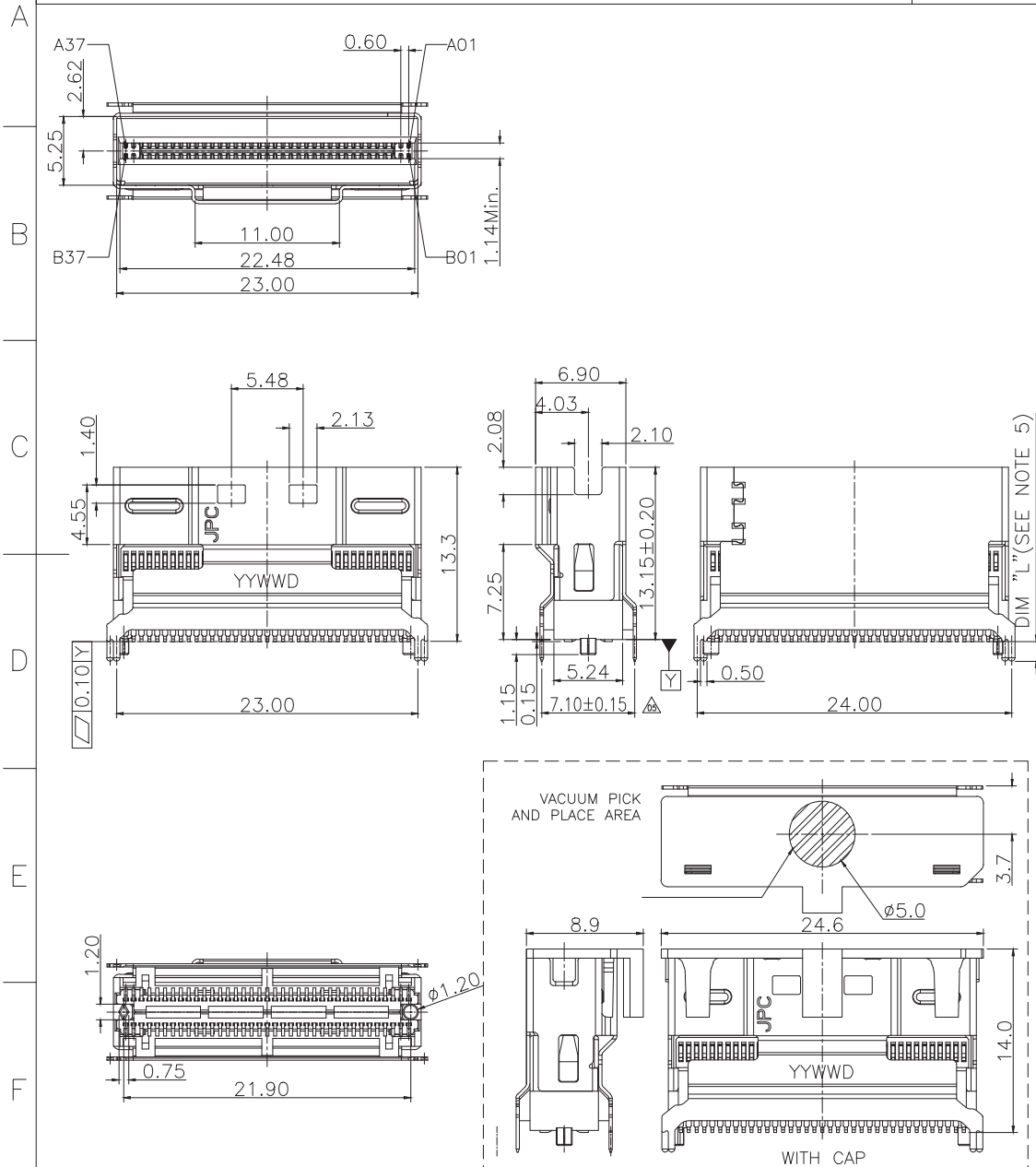

WITH CAP

NOTE:
 1.MATERIAL:
 HOUSING:HI-TEMP THERMOPLASTIC UL 94V-0 BLACK
 TERMINAL:COPPER ALLOY
 SHELL:STAINLESS STEEL
 *CAP:HI-TEMP THERMOPLASTIC UL 94V-0 BLACK(SEE JPC P/N MATRIX)
 2.PLATING:
 TERMINAL:CONTACT & SOLDER AREA SEE JPC P/N MATRIX
 30u" MIN. NICKEL UNDERPLATE ALL OVER
 SHELL:30u" MIN. NICKEL PLATED ALL OVER
 3.DATE CODE: YYWWD
 YY=THE LAST 2 DIGITS OF THE YEAR
 WW=WEEK OF MANUFACTURE
 D=DAY FOR WEEK
 4.PACKAGE SPEC : SOP-PK-P935A074-D
 5.JPC P/N MATRIX: P 9 3 5 A 0 7 4 * * * * - 0
 Thinline SAS 8i RECEPTACLE
 85 Ohm VERTICAL SMT SERIES
 SHELL ATTACH
 A: OUTSIDE DIP TYPE
 POS
 074: 74POS(8i)
 OTHER
 PACKAGE
 R: TAPE & REEL W/Pitch 20mm (STD)
 S: TAPE & REEL W/Pitch 24mm
 OPTIONAL:
 B: W/ CAP BLACK
 N: W/O CAP
 TAIL LENGTH=DIM "L"
 1: DIP, L=3.0mm(For PCB:2.4-2.8mm)
 2: DIP, L=1.5mm(For PCB:0.7-1.3mm)
 3: DIP, L=2.2mm(For PCB:1.6-2.0mm)

RoHS COMPLIANT	HALOGEN FREE	Unit : mm	PROJECTION	JPC JESS-LINK PRODUCTS CO., LTD.		
		GENERAL TOLERANCES: (UNLESS SPECIFIED)		TITLE	Thinline SAS 8i Conn.	
		0 = ±.30	D.R. 07/20/2018	Denghong	(85 Ohm, REC. V/T, SMT, H=13.3mm)	PRODUCT NO. /LAYOUT C16HO344A
		0.0 = ±.20 0.00 = ±.10 0.000 = ±.05 0' = ±.1' 0.0' = ±.50'	CH.K 07/20/2018	Andrew	SCALE SIZE	2:1 A4
	APV.D 07/20/2018	Pc Liao	DWG NO.	SD-P935A074-D	REV. 05	
					SHEET 1 OF 2	

THIS DRAWING AND THE DATA DISCLOSED HEREIN OR HEREWITH IS NOT TO BE REPRODUCED USED OR DISCLOSED IN WHOLE OR IN PART TO ANYONE WITHOUT THE PERMISSION OF JESS-LINK PRODUCTS CO.,LTD.

CUSTOMER DRAWING

REV.	DESCRIPTION	MDF'D	APP'D	DATE
01	INITIAL DESIGN	Bob	Ray	09/30/2016
04	MODIFY PRODUCT DESCRIPTION	Jemmy	Ray	09/18/2017
05	PITCH28mm change to PITCH24mm	denghong	Pc Liao	07/20/2018

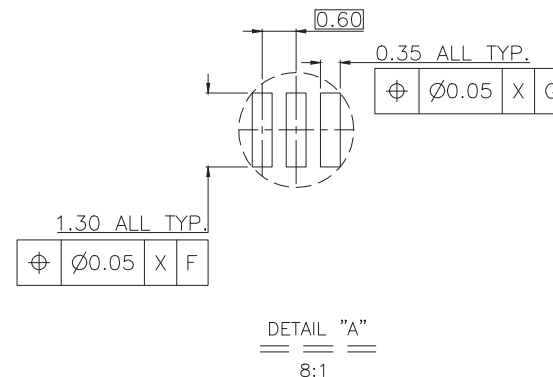
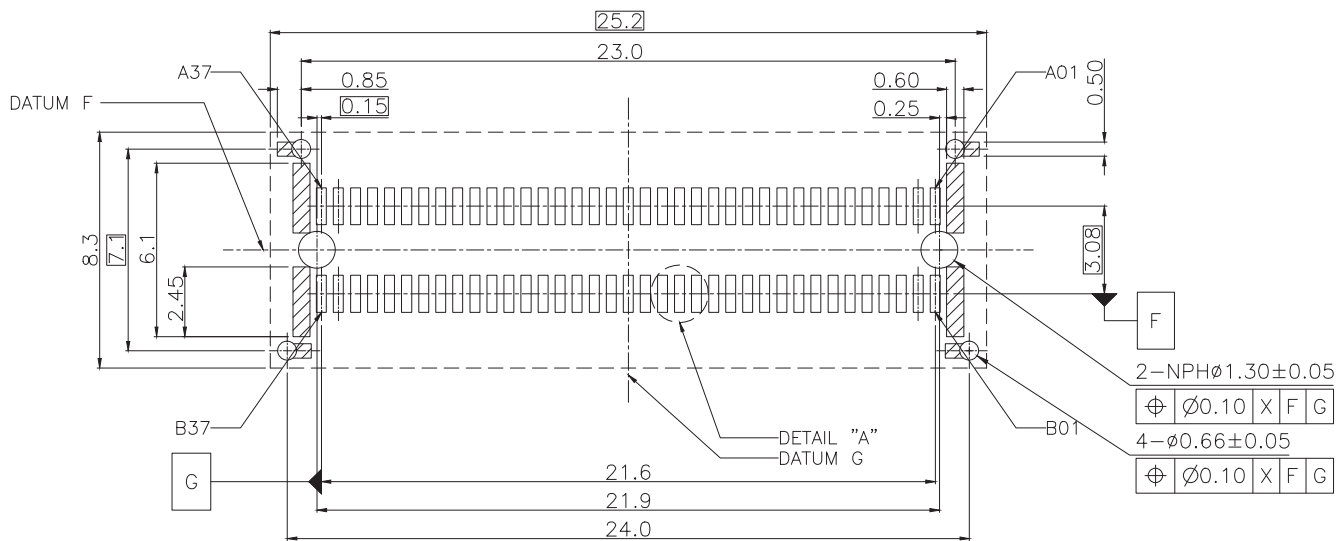

RECOMMENDED PCB LAYOUT

RoHS COMPLIANT	HALOGEN FREE	Unit : mm	PROJECTION 		JPC JESS-LINK PRODUCTS CO., LTD.			
		GENERAL TOLERANCES: (UNLESS SPECIFIED)	D.R. 07/20/2018 Denghong	TITLE Thinline SAS 8i Conn. (85 Ohm, REC. V/T, SMT, H=13.30mm)			PRODUCT NO. /LAYOUT C16HO344A	
		0 = ±.30 0.0 = ±.20 0.00 = ±.10 0.000 = ±.05 0' = ± 1' 0.0' = ±.50'	CH.K 07/20/2018 Andrew	SCALE	SIZE	DWG NO.		REV. 05
			APV.D 07/20/2018 Pc Liao	4:1	A4	SD-P935A074-D		SHEET 2 OF 2