

THIS DRAWING AND THE DATA DISCLOSED HEREIN OR HEREWITH IS NOT TO BE REPRODUCED USED OR DISCLOSED IN WHOLE OR IN PART TO ANYONE WITHOUT THE PERMISSION OF JESS-LINK PRODUCTS CO.,LTD. THIS PART SHOULD NOT CONTAIN ANY SUBSTANCES WHICH ARE SPECIFIED IN SS-00259-01. PURCHASE RECYCLED RESINS AND WIRE RODS ONLY FROM SONY QUALIFIED VENDORS.

CUSTOMER DRAWING

REV.	ECN NO.	DESCRIPTION	MDF'D	APP'D	DATE
A	ECN-1011018	INITIAL DESIGN	Andrew	Richard	11/11/10*
E5	ECN-057416	ADD NEW PART NO.	Haijian	Richard	07/28/15*
E6	ECN-072495	CHANGE DRAWING NO.	Semin	Richard	10/31/18**



1 LOT NUMBER ORDERING

 ** * **
 CODE:01,02...99...A0,A1
 TEAM CODE:A,B,C...1,2,3
 MONTH CODE:1,2,3...A,B,C
 YEAR CODE:0,1,2,3...

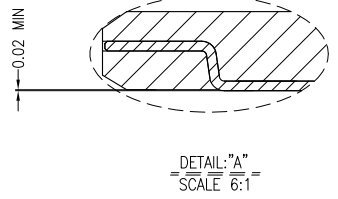
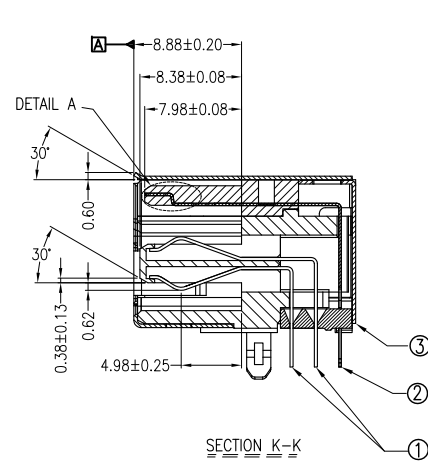
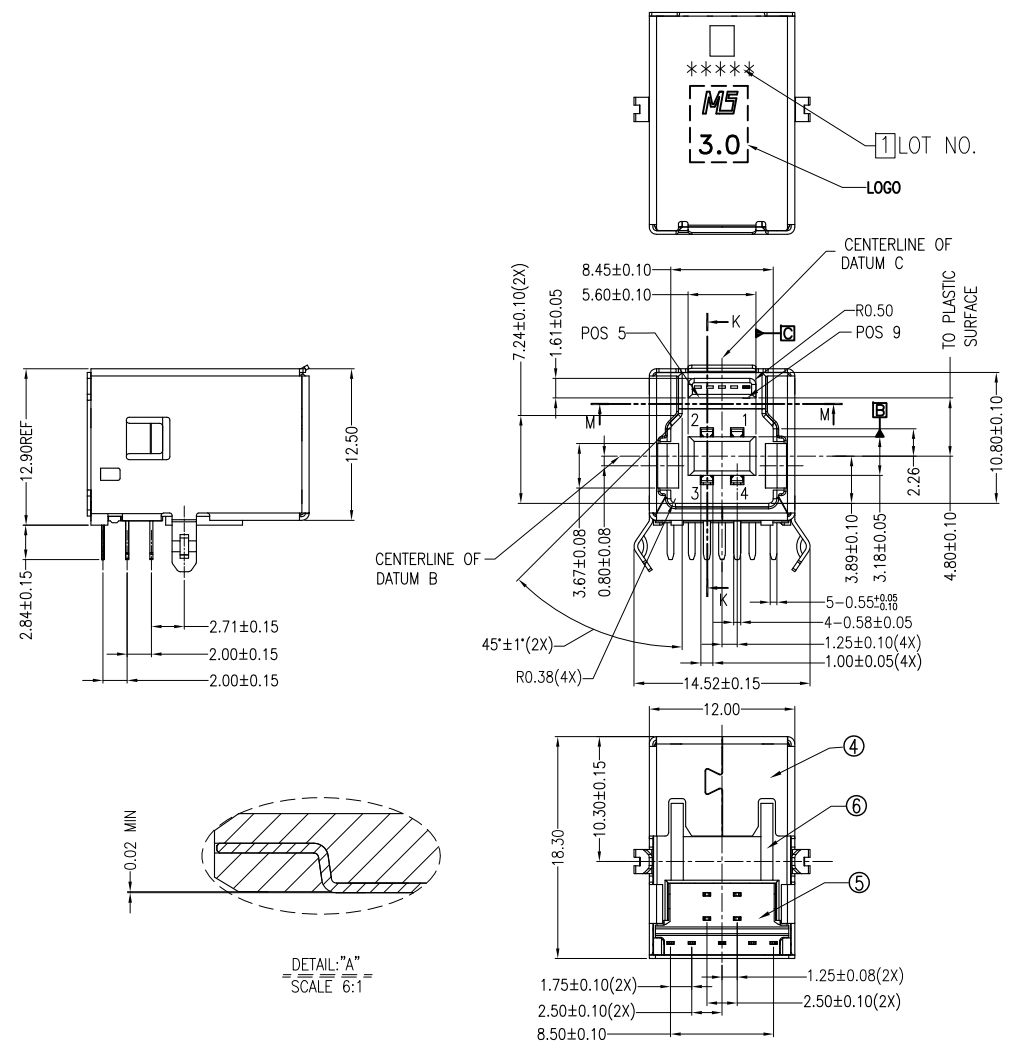

NEW DRAWING NO.	OLD DRAWING NO.
UCNTB019E009-0	0000404-1001

ITEM	PART	DESCRIPTION	PART NUMBER	Q'TY	RoHS COMPLIANT	HALOGEN FREE	Unit : mm	PROJECTION	JPC JESS-LINK PRODUCTS CO., LTD.			
6	HOUSING	HIGH TEMPERATURE THERMOPLASTICS,UL94V-0,COLOR:SEE NOTE			RoHS COMPLIANT	HALOGEN FREE	GENERAL TOLERANCES: (UNLESS SPECIFIED) 0 = ±.50 0.0 = ±.25 0.00 = ±.15 0.000 = ±.05 0° = ± 1° 0.0° = ±.50°	D.R. 10/31/18* Semin	TITLE USB 3.0 STANDARD B F DIP 90° TYPE	PRODUCT NO. OR LAYOUT		
5	SPACER	HIGH TEMPERATURE THERMOPLASTICS,UL94V-0,COLOR:SEE NOTE										
4	SHELL	STAINLESS STEEL,T=0.30mm,OVER-PLATING:Ni 30u"										
3	COVER SHELL	SPCC T=0.30mm,OVER-PLATING:Ni 80u"										
2	5P TERMINAL	COPPER ALLOY T=0.20mm UNDER-PLATING&CONTACT AREA:SEE NOTE,SOLDER AREA: Sn 120u"										
1	2P TERMINAL	COPPER ALLOY T=0.25mm UNDER-PLATING&CONTACT AREA:SEE NOTE,SOLDER AREA: Sn 120u"										
								APV.D 10/31/18* Richard	SCALE 1.5:1	SIZE A4	DWG NO. UCNTB019E009-0	REV. E6 SH,T NO. 1 OF 2

1 2 3 4 5 6 7 8

THIS DRAWING AND THE DATA DISCLOSED HEREIN OR HEREWITH IS NOT TO BE REPRODUCED USED OR DISCLOSED IN WHOLE OR IN PART TO ANYONE WITHOUT THE PERMISSION OF JESS-LINK PRODUCTS CO.,LTD.

CUSTOMER DRAWING

REV.	ECN NO.	DESCRIPTION	MDF'D	APP'D	DATE
A	ECN-1011018	DRAWING RELEASE		Richard	11/11/2010
E4	ECN-057416	ADD NEW PART NO	HaiJian	Richard	07/28/2015
E5	ECN-072356	CANCEL TRAY LABEL AND CHANGE DRAWING NO.	HaiBin	Richard	10/11/2018

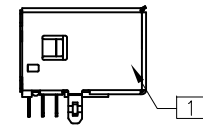

PRODUCT(P/N :UCNT*O*E***~*)
產品 (料號 :UCNT*O*E***~*)

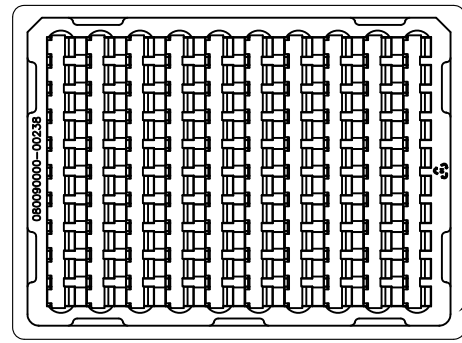

TRAY (P/N:KPP0004762)
真空盒下蓋 (料號:KPP0004762)

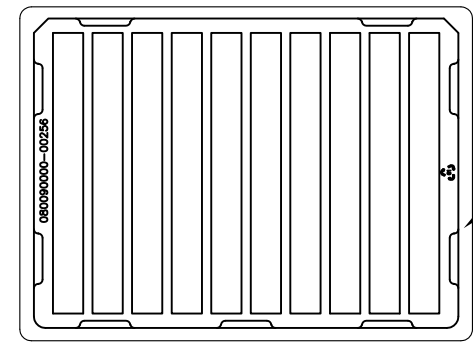

TRAY (P/N:KPP0004774)
真空盒上蓋 (料號:KPP0004774)

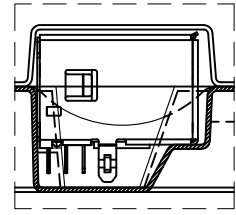

DET.A
6:1

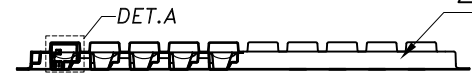

STICK LABEL IN THIS PLACE
貼外箱標貼處

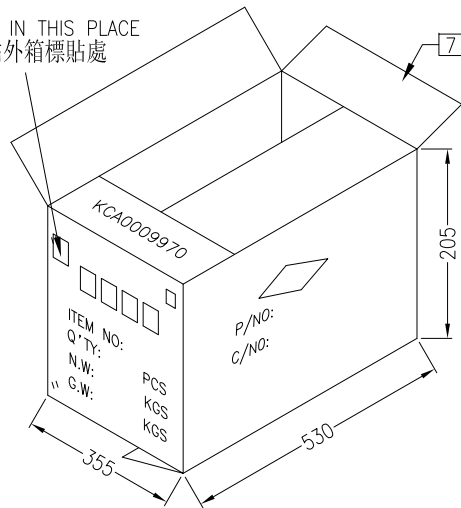

OUTER CARTON(P/N : KCA0009970)
外紙箱 (料號 : KCA0009970)

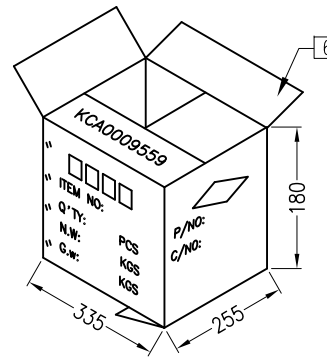

INNER CARTON(P/N : KCA0009559)
內紙箱 (料號 : KCA0009559)

PE BAG(P/N : KBA0007715)
PE袋 (料號 : KBA0007715)

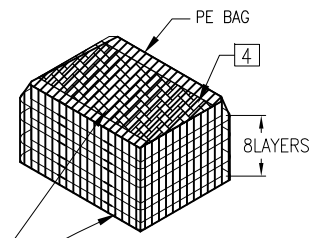

頂面1個紙板，底面兩個紙板后，用熱封膜包裝好
1PRESSBOARD/TOP, 2PRESSBOARD/BOTTOM
AND WRAPPED BY HEAT SEALING

ITEM	PART	DESCRIPTION	PART NUMBER	Q'TY
7	OUTER CARTON	K=A, (外紙箱)	KCA0009970	1
6	INNER CARTON	B=B, (內紙箱)	KCA0009559	2
5	PE BAG	PE , (PE袋)	KBA0007715	2
4	PRESSBOARD	B=C, (紙板) L*W=280*220 T=3.00	KCA0009591	6
3	TRAY COVER	PET , TRANSPARENCE, (真空盒上蓋)	KPP0004774	16
2	TRAY	PET ,TRANSPARENCE, (真空盒下蓋)	KPP0004762	16
1	PRODUCT	UCNT*O*E***~*		1600

RoHS COMPLIANT		HALOGEN FREE		Unit : mm		PROJECTION		JPC JESS-LINK PRODUCTS CO., LTD.	
				GENERAL TOLERANCES: (UNLESS SPECIFIED)		D.R. 10/11/2018		TITLE USB 3.0 STANDARD B F DIP 90°	
				0 = ±.30		HaiBin		PRODUCT NO. OR LAYOUT	
				0.0 = ±.20		CH.K 10/11/2018		TYPE (PACKING DRAWING)	
				0.00 = ±.10		Andrew		SCALE N/A	
				0.000 = ±.05		APV.D 10/11/2018		SIZE A4	
				0° = ± 1'		Richard		DWG NO. SOP-PK-UCNTB019E009-0	
				0.0° = ±.50°				REV. E5	
								SH,T NO. 1 OF 2	

THIS DRAWING AND THE DATA DISCLOSED HEREIN OR HEREWITH IS NOT TO BE REPRODUCED USED OR DISCLOSED IN WHOLE OR IN PART TO ANYONE WITHOUT THE PERMISSION OF JESS-LINK PRODUCTS CO.,LTD.

CUSTOMER DRAWING

REV.	ECN NO.	DESCRIPTION	MDF'D	APP'D	DATE
A	ECN-1011018	DRAWING RELEASE		Richard	11/11/2010
E4	ECN-057416	ADD NEW PART NO	HaiJian	Richard	07/28/2015
E5	ECN-072356	CANCEL TRAY LABEL AND CHANGE DRAWING NO.	HaiBin	Richard	10/11/2018



i1 PART NO.	TIPTOP PART NO.	LOGO
UCNTB018E009-0	000040401-00007	NO LOGO
▲ UCNTB019E009-0	000040401-00008	"MS 3.0" LOGO
UCNTC001EC72-0	_____	"MS 3.0" LOGO
UCNTB018E009-2	_____	NO LOGO

NOTE 1 : " ▲ " IS STANDARD PRODUCT

ES NOTE 2:

OLD DRAWING NO.	NEW DRAWING NO.
SOP-PK-10000404-001	SOP-PK-UCNTB019E009-0

序號 NO.	項 目 ITEM	
1	包裝方式 Method of packing	UCNT*0*E***_*
2	包裝方式說明 Packing instruction	
3	內包裝單位 Unit of inner packing	箱 CARTON
4	內包裝含產品數量 Inner packing quantity	800 PCS
5	內包裝重量(g) Inner packing weight	1312
6	外包裝含內包裝數量 Quantity of inner packing	2
7	外包裝單位 Unit of outer packing	箱 CARTON
8	外包裝重量(g) Weight of outer packing	800
9	總數量 (PCS) Total quantity	1600 PCS
10	長Length(mm)x寬Width(mm)x高High(mm)	530x355x205
11	數量/盤: 1.QUANTITY/TARY	100 PCS
12	淨重/箱 WEIGHT/CARTON:N.W	7.50 Kg
13	毛重/箱 WEIGHT/CARTON:G.W	10.95±0.30Kg
14	TRAY EVERY 8 LAYERS WERE PACKING BY PE FILM 每 8 盤用 熱封膜包裝好	

RoHS COMPLIANT	HALOGEN FREE	Unit : mm	PROJECTION 		JPC JESS-LINK PRODUCTS CO., LTD.		
		GENERAL TOLERANCES: (UNLESS SPECIFIED)	D.R. 10/11/2018 HaiBin	TITLE USB 3.0 STANDARD B F DIP 90° TYPE (PACKING DRAWING)			PRODUCT NO. OR LAYOUT
		0 = ±.30 0.0 = ±.20 0.00 = ±.10 0.000 = ±.05 0° = ± 1° 0.0° = ±.50°	CH.K 10/11/2018 Andrew	SCALE	SIZE	DWG NO.	REV. E5
			APV.D 10/11/2018 Richard	N/A	A4	SOP-PK-UCNTB019E009-0	SH,T NO.2 OF 2