

THIS DRAWING AND THE DATA DISCLOSED HEREIN OR HEREWITH IS NOT TO BE REPRODUCED USED OR DISCLOSED IN WHOLE OR IN PART TO ANYONE WITHOUT THE PERMISSION OF JESS-LINK PRODUCTS CO.,LTD.

CUSTOMER DRAWING

REV.	ECN NO.	DESCRIPTION	MDF'D	APP'D	DATE
01		DRAWING RELEASE	Corá	Richard	05/25/12*
04	ECN-047774	DRAWING UP VERSION	Zhi_Wang	Richard	10/17/13*
05	ECN-072495	MODIFY PICTURE FRAME	Colin	Richard	11/01/18*

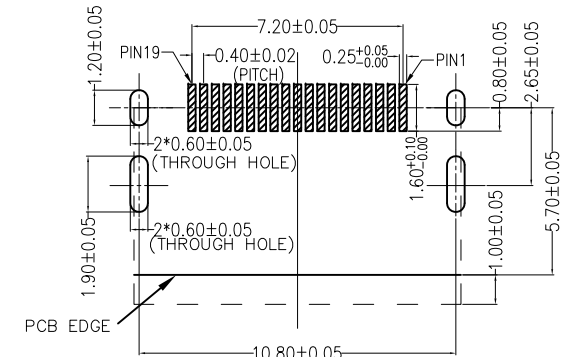
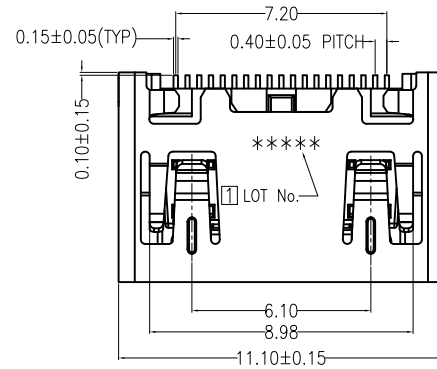
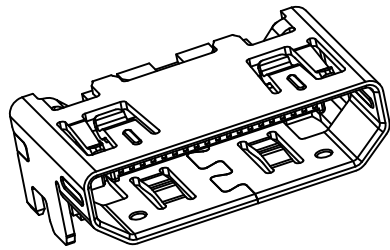

RECOMMENDED PCB LAYOUT(t=0.60±0.10)
COMPONENT SIDE

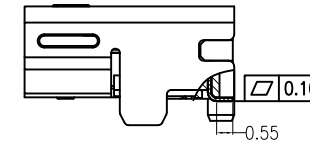
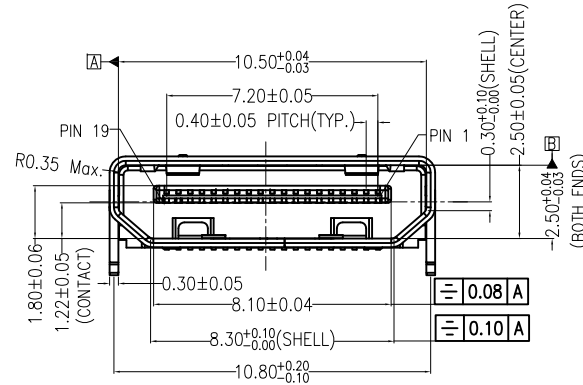
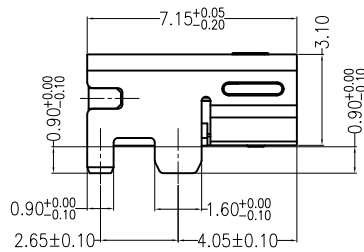

NOTE: [] LOT NUMBER ORDERING:

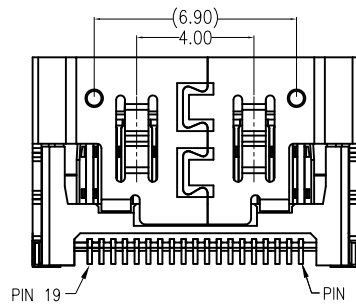
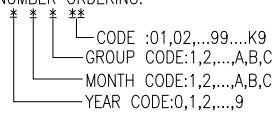

NOTE:

- MATERIAL:
HOUSING: HI-TEMP THERMOPLASTIC UL 94V-0 BLACK
TERMINAL: COPPER ALLOY
SHELL: STAINLESS STEEL
- PLATING:
TERMINAL: CONTACT AREA: G/F
UNDER-PLATING: Ni 30u"
SOLDER AREA: G/F
SHELL: NICKEL OVER 30u"
- PACKAGE: TAPE & REEL

RoHS COMPLIANT	HALOGEN FREE	Unit : mm	PROJECTION	JPC JESS-LINK PRODUCTS CO., LTD.	
		GENERAL TOLERANCES: (UNLESS SPECIFIED)	D.R. Colin		
		0 = ±.50	CH.K Andrew	HDMI-C F SMT RA 19PIN Slim Type IV CONNECTOR	C12N0104A
		0.0 = ±.25 0.00 = ±.15 0.000 = ±.05 0° = ± 1° 0.0° = ± 1'	APV.D Richard	SCALE 4:1	SIZE A4
					SH,T NO. 1 OF 1

THIS DRAWING AND THE DATA DISCLOSED HEREIN OR HEREWITH IS NOT TO BE REPRODUCED USED OR DISCLOSED IN WHOLE OR IN PART TO ANYONE WITHOUT THE PERMISSION OF JESS-LINK PRODUCTS CO.,LTD.

CUSTOMER DRAWING

REV.	ECN NO.	DESCRIPTION	MDF'D	APP'D	DATE
A1	ECN-063860	NEW DRAWING RELEASE	ZHI WEI	RICHARD	12/02/16*
A2	ECN-072495	MODIFY PICTURE FRAME	COLIN	RICHARD	11/01/18*



NOTES:

- QUANTITY/REEL: 700 PCS/REEL
數量/盤 : 700PCS/盤
QUANTITY/INNER CARTON: 700 X 5 = 3500 PCS
數量/內箱 : 700 X 5 = 3500 PCS
QUANTITY/OUTER CARTON: 3500 X 2 = 7000 PCS
數量/外箱 : 3500 X 2 = 7000 PCS
- FREE 30 PRODUCT IN THE FRONT CARRIER AND FREE 5 PRODUCT IN THE END CARRIER./ 包裝帶頭部空 30 格, 尾部空 5 格
- 尾數箱用氣泡墊裝滿
- Lot No.
CODE :01,02,...99...K9
MONTH CODE:1,2,...,A,B,C
YEAR CODE:0,1,2,...,9

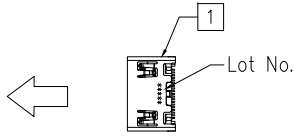
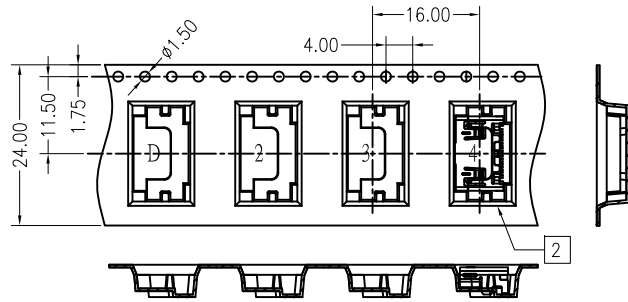

USER DIRECTION OF FEED

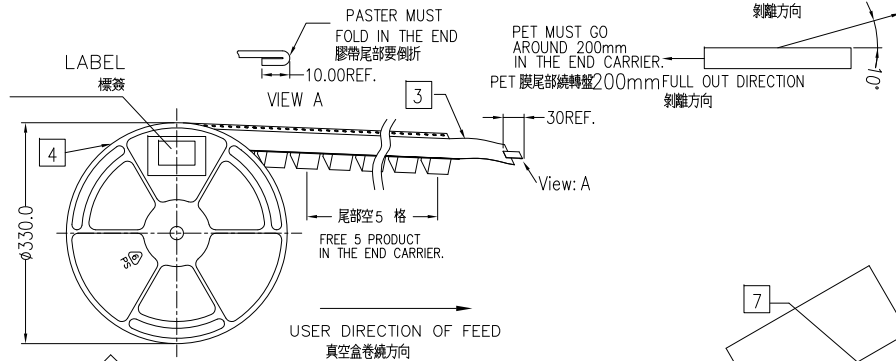

USER DIRECTION OF FEED
真空盒卷繞方向

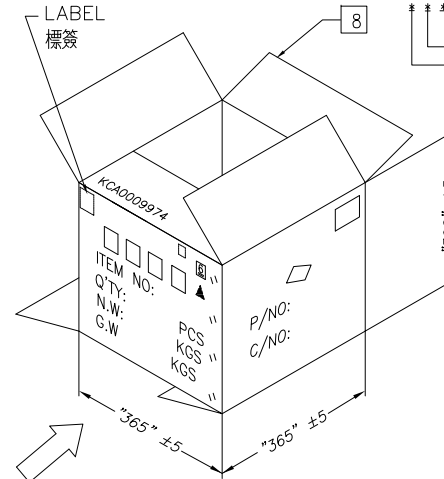
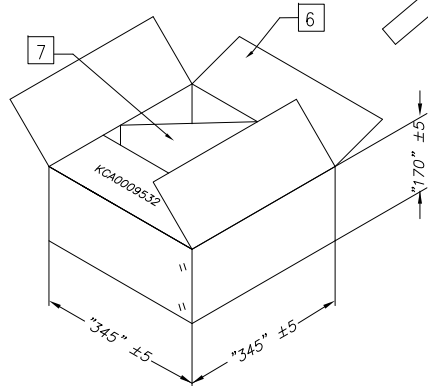
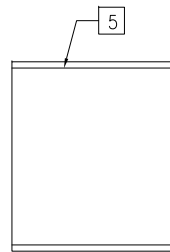
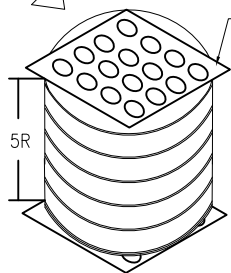

序號 NO.	項 目 ITEM	
1	包裝方式 Method of packing	UCNRB003AC42-0
2	包裝方式說明 Packing instruction	
3	內包裝單位 Unit of inner packing	箱 CARTON
4	內包裝含產品數量 Inner packing quantity	3500 PCS
5	內包裝重量(g) Inner packing weight	3940 g
6	外包裝單位 Unit of outer packing	箱 CARTON
7	外包裝含內包裝數量 Quantity of inner packing	2
8	外包裝重量(g) Weight of outer packing	740 g
9	總數量(PCS) Total quantity	7000 PCS
10	長Length (mm) x 寬Width (mm) x 高High (mm)	365x365x390
11	數量/盤 1. QUANTITY/Reel	700 PCS
12	淨重/箱 WEIGHT/CARTON:N.W	3.01 KG
13	毛重/箱 WEIGHT/CARTON:G.W	8.6±0.30 KG

ITEM	PART	DESCRIPTION	PART NUMBER	Q'TY
9	AIR CUSHION		KFO0002190	4
8	OUTER CARTON	K=A	KCA0009974	1
7	A TYPE PAD	B=B	KCA0009597	8
6	INNER CARTON	K=A	KCA0009532	2
5	PE BAG		KBA0007728	2
4	PLASTIC TRAY	PS,T=2.0,BLUE	KPP0005971	10
3	COVER TAPE	PET	KPP0004658	
2	CARRIER TAPE	PS,T=0.40,BLACK	KPP0006059	
1	PRODUCT		UCNRB003AC42-0	7000

RoHS COMPLIANT

HALOGEN FREE

Unit : mm
GENERAL TOLERANCES: (UNLESS SPECIFIED)
±0.3
0.0 = ±0.20
0.00 = ±0.10
0.000 = ±0.05
0° = ±1'
0.0° = ±0.50'

PROJECTION
D.R. Colin
CH.K Andrew
APV.D Richard

JPC JESS-LINK PRODUCTS CO., LTD.

TITLE HDMI-C F SMT RA 19PIN I-M SPECIFICATION

SCALE N/A	SIZE A4	DWG NO. SOP-PK-UCNRB003AC42-0	REV. A2	PRODUCT NO. OR LAYOUT C12N0104A	SH,T NO. 1 OF 1
-----------	---------	-------------------------------	---------	---------------------------------	-----------------